

# 40V Step-Up Regulator for White LED Driver with PWM Dimming

## DESCRIPTION

The ETA1168 is a high efficiency step-up converter with an internally integrated 40V power MOSFET. It runs with an optimal 600KHz frequency that enables the use of small external components while still providing the best efficiency. It can drive up to 10 to 12 LEDs in series and also in parallel combinations. The incorporated true PWM-Dimming feature through CTRL pin does not generate audible noise on the output capacitor during dimming because it does not burst the LED current. For maximum protection, the ETA1168 has an OVP protection feature that prevents the output voltage exceeding the maximum rating of the ETA1168 and the output cap during open-LED conditions.

ETA1168 is available in a space-saving DFN22-6 package.

## FEATURES

- Up to 92% Efficiency
- 40V OVP protection
- True PWM Brightness Control
- 200mV Feedback Voltage
- DFN2x2-6 Package

## APPLICATIONS

- LED Backlighting for Tablets, MID's and Smartphones
- LED Driver

## ORDERING INFORMATION

PART #	PACKAGE PIN	TOP MARK
ETA1168D2G-T	DFN2x2-6	DGYW └── Date Code └── Product Number

## TYPICAL APPLICATION

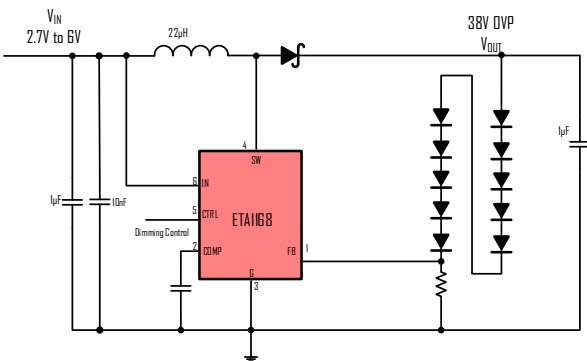

\*note: The input capacitor is recommended to be 1µF/10nF to have least influence to the RF system

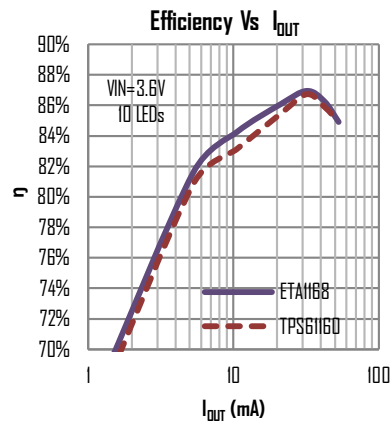

*Same Board, same everything else, ETA1168 beats TI's TPS61160 in Efficiency handily across the board*