

■ INTRODUCTION

The CE8808 Series is a series of high-precision voltage detectors developed using CMOS process. The detection voltage is fixed internally, with an accuracy of 2.0%. Two output forms, NMOS open-drain and CMOS output, are available.

■ FEATURES

- Ultra-low current consumption: 0.9μA@3.5V(Typ.)
- High-precision detection voltage:±2.0%
- Operating voltage range:0.95 V~ 7.0V
- Hysteresis characteristics: -V<sub>DET</sub>×5% (Typ.)
- Detection voltage: 1.5V ~ 6.0V(10mV step)
- Output forms:  
NMOS open-drain output (Active Low)  
CMOS output (Active Low)

■ APPLICATIONS

- Memory battery back-up circuits
- Power-on reset circuits
- Power failure detection
- Power monitor for portable equipment such as notebook computers, digital cameras, PDA, and cellular phones.
- Constant voltage power monitors for cameras, video equipment and communication devices.
- Power monitor for microcomputers and reset for CPUs.

■ ORDER INFORMATION

CE8808①②③④⑤

DESIGNATOR	SYMBOL	DESCRIPTION
①	C	CMOS
	N	NMOS open drain
②③④	Integer	Detection Voltage (1.50V~6.00V), “④”elide when it is “0” e.g. 3.0V=②:3, ③:0 2.93V=②:2, ③:9, ④:3
⑤	M/MA/MB/MR	Package: SOT-23,SOT-23-3/5
	N	Package: SOT-343(SC-82)
	P	Package: SOT-89-3
	T/TA	Package: TO-92

■ BLOCK DIAGRAMS

NMOS open-drain

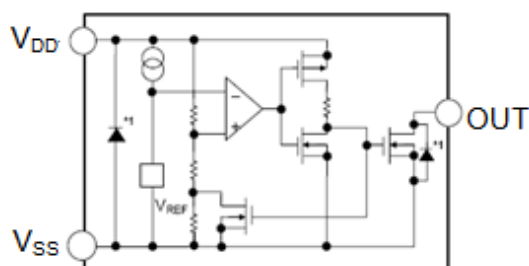

CMOS output

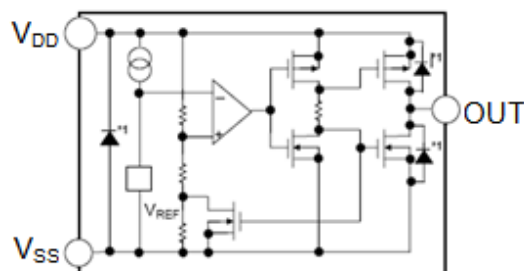

■ PIN CONFIGURATION

SOT-23-3  
Top view

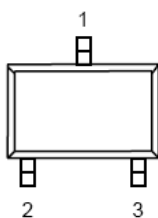

CE8808 Series (SOT-23-3/SOT-23)

PIN NO.	M	MA	MB	FUNCTION
1	V <sub>DD</sub>	V <sub>DD</sub>	V <sub>DD</sub>	Voltage input pin
2	V <sub>OUT</sub>	-	V <sub>OUT</sub>	Voltage detection output pin
	-	V <sub>SS</sub>	-	Ground
3	V <sub>SS</sub>	-	V <sub>SS</sub>	Ground
	-	V <sub>OUT</sub>	-	Voltage detection output pin

SOT-23-5  
Top view

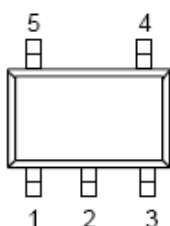

CE8808 Series (SOT-23-5)

PIN NO.	MR	FUNCTION
1	V <sub>OUT</sub>	Voltage detection output pin
2	V <sub>DD</sub>	Voltage input pin
3	V <sub>SS</sub>	Ground
4	NC	No connection
5	NC	No connection

SOT-89-3  
Top view

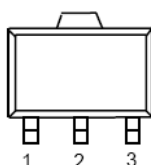

CE8808 Series (SOT-89-3)

PIN NO.	P	FUNCTION
1	V <sub>OUT</sub>	Voltage detection output pin
2	V <sub>DD</sub>	Voltage input pin
3	V <sub>SS</sub>	Ground

CE8808 Series (TO-92)

TO-92  
Bottom view



PIN NO.	T	TA	FUNCTION
1	V <sub>OUT</sub>	-	Voltage detection output pin
	-	V <sub>DD</sub>	Voltage input pin
2	V <sub>DD</sub>	-	Voltage input pin
	-	V <sub>SS</sub>	Ground
3	V <sub>SS</sub>	-	Ground
	-	V <sub>OUT</sub>	Voltage detection output pin

SOT343(SC-82)  
Top view

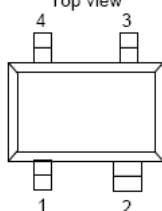

CE8808 Series (SOT343)

PIN NO.	N	FUNCTION
1	V <sub>OUT</sub>	Voltage detection output pin
2	V <sub>DD</sub>	Voltage input pin
3	NC	No Connection
4	V <sub>SS</sub>	Ground

## ■ ABSOLUTE MAXIMUM RATINGS

(Ta=25°C, unless otherwise specified)

PARAMETER		SYMBOL	RATINGS	UNITS
Power supply voltage		$V_{DD}$	$V_{SS}-0.3 \sim V_{SS}+8$	V
Output voltage		$V_{OUT}$	$V_{SS}-0.3 \sim V_{SS}+8$	V
Power dissipation	SOT-23-3	PD	250	mW
	SOT-89		500	mW
	TO-92		500	mW
	SOT343		250	mW
Operating ambient temperature		$T_{opr}$	-40 ~ +85	°C
Storage temperature		$T_{stg}$	-40 ~ +125	°C
Soldering Temperature & Time		$T_{solder}$	260°C, 10s	

## ■ ELECTRICAL CHARACTERISTICS

(Ta=25°C, unless otherwise specified)

PARAMETER	SYMBOL	CONDITIONS		MIN	TYP	MAX	UNITS
Detection voltage*1	$-V_{DET}$	—		$-V_{DET(S)} \times 0.98$	$-V_{DET(S)}$	$-V_{DET(S)} \times 1.02$	V
Hysteresis width	$V_{HYS}$	—		$0.02 \times -V_{DET(S)}$	$0.05 \times -V_{DET(S)}$	$0.08 \times -V_{DET(S)}$	V
Current consumption	$I_{SS}$	$V_{DD} = -V_{DET} + 0.5V$	CE8808C/N20~26	—	1.0	2.0	uA
			CE8808C/N 26~39	—	1.2	2.5	uA
			CE8808C/N 39~60	—	1.5	3.0	uA
Operating voltage	$V_{DD}$	—		0.95	—	7	V
Output current	$I_{OUT}$	NMOS: $V_{OUT} = 0.5V$ $V_{DD} = -V_{DET} - 0.5V$	CE8808C/N 20~26	3.0	13.0	—	mA
			CE8808C/N 26~39	3.0	15.0	—	mA
			CE8808C/N 39~60	3.0	18.0	—	mA
		PMOS: $V_{DD} - V_{OUT} = 0.5V$ $V_{DD} = -V_{DET} + 0.5V$	CE8808C/N 20~26	1.5	4.0	—	mA
			CE8808C/N 26~39	1.5	6.0	—	mA
			CE8808C/N 39~60	1.5	8.0	—	mA
Leakage current	$I_{LEAK}$	Only for NMOS open-drain output products, $V_{DD} = 8.0V, V_{OUT} = 8.0V$		—	—	1.0	uA
temperature coefficient		Ta=-40°C ~+85°C		—	±120	±360	ppm/°C
Delay time	$T_{PLH}$				200		us

\*1. -VDET: Actual detection voltage value, -VDET(S): Specified detection voltage value

## ■ FUNCTIONAL DESCRIPTION

1. When a voltage higher than the release voltage ( $+V_{DET}$ ) is applied to the voltage input pin ( $V_{DD}$ ), the voltage will gradually fall. When a voltage higher than the detect voltage ( $-V_{DET}$ ) is applied to  $V_{DD}$ , output ( $V_{OUT}$ ) will be equal to the input at  $V_{DD}$ .

Note that high impedance exists at  $V_{OUT}$  with the N-channel open drain configuration. If the pin is pulled up,  $V_{OUT}$  will be equal to the pull up voltage.

2. When  $V_{DD}$  falls below  $-V_{DET}$ ,  $V_{OUT}$  will be equal to the ground voltage ( $V_{SS}$ ) level (detect state).

Note that this also applies to N-channel open drain configurations.

3. When  $V_{DD}$  falls to a level below that of the minimum operating voltage ( $V_{MIN}$ ) output will become unstable.

Because the output pin is generally pulled up with N-channel open drain configurations, output will be equal to pull up voltage.

4. When  $V_{DD}$  rises above the  $V_{SS}$  level (excepting levels lower than minimum operating voltage),  $V_{OUT}$  will be equal to  $V_{SS}$  until  $V_{DD}$  reaches the  $+V_{DET}$  level.

5. Although  $V_{DD}$  will rise to a level higher than  $+V_{DET}$ ,  $V_{OUT}$  maintains ground voltage level via the delay circuit.

6. Following transient delay time,  $V_{DD}$  will be output at  $V_{OUT}$ .

Note that high impedance exists with the N-channel open drain configuration and that voltage will be dependent on pull up.

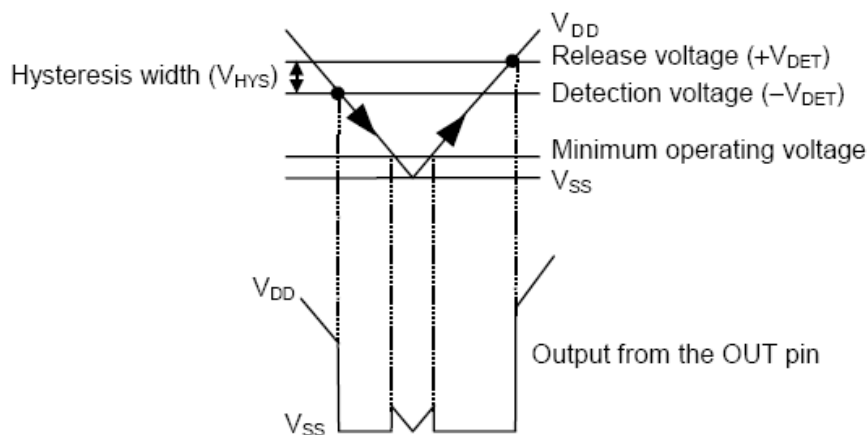

■ TYPICAL APPLICATION CIRCUITS

1、CMOS output:

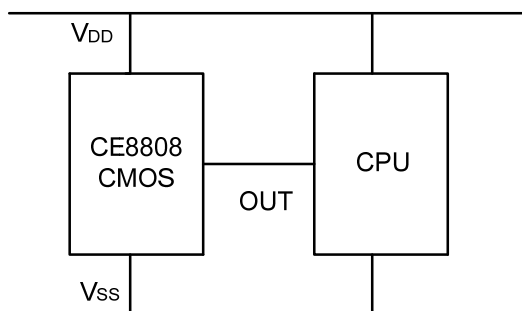

2、NMOS open-drain

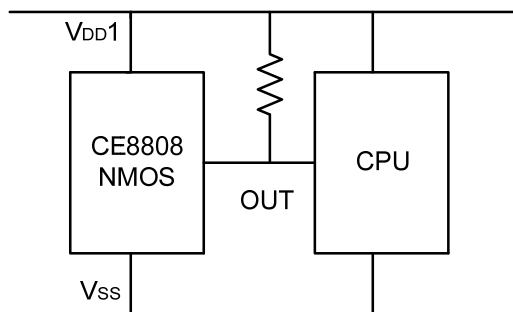
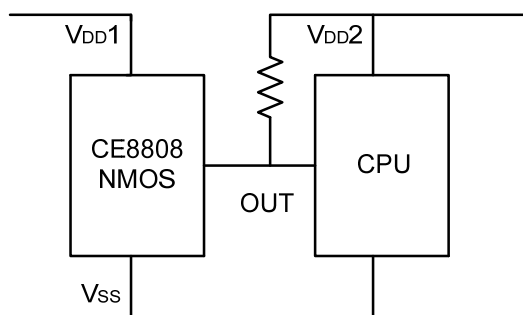

3. Forbidden Circuits

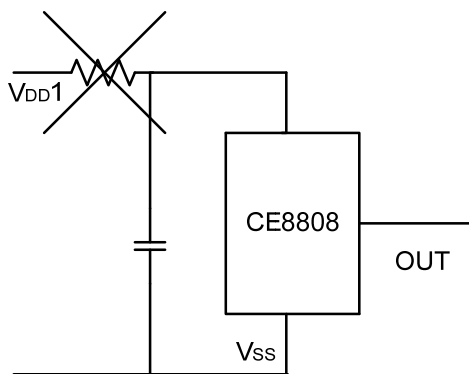

■ PACKAGING INFORMATION

- SOT-23-3

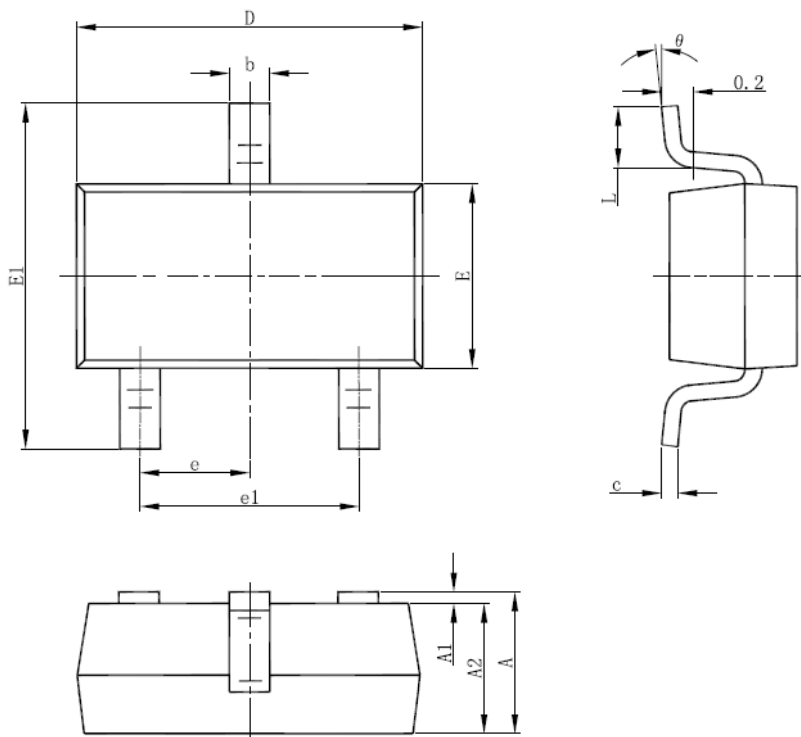

Symbol	Dimensions In Millimeters		Dimensions In Inches	
	Min	Max	Min	Max
A	1.050	1.250	0.041	0.049
A1	0.000	0.100	0.000	0.004
A2	1.050	1.150	0.041	0.045
b	0.300	0.500	0.012	0.020
c	0.100	0.200	0.004	0.008
D	2.820	3.020	0.111	0.119
E	1.500	1.700	0.059	0.067
E1	2.650	2.950	0.104	0.116
e	0.950(BSC)		0.037(BSC)	
e1	1.800	2.000	0.071	0.079
L	0.300	0.600	0.012	0.024
$\theta$	0°	8°	0°	8°

• SOT-23

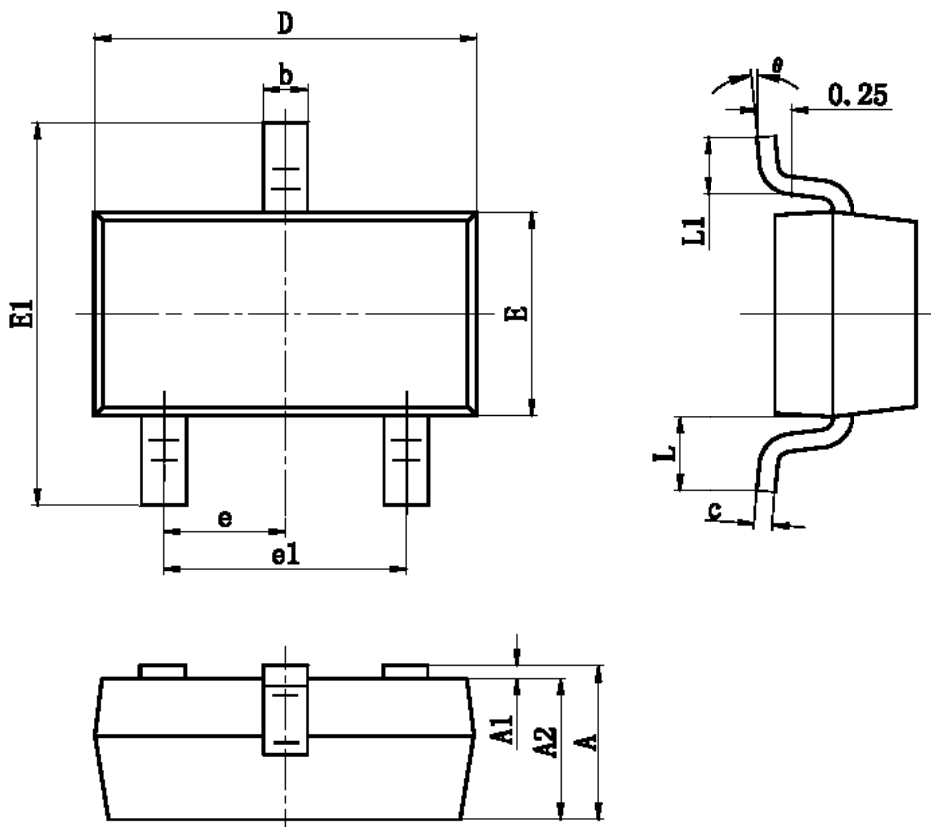

Symbol	Dimensions In Millimeters		Dimensions In Inches	
	Min	Max	Min	Max
A	0.900	1.150	0.035	0.045
A1	0.000	0.100	0.000	0.004
A2	0.900	1.050	0.035	0.041
b	0.300	0.500	0.012	0.020
c	0.080	0.150	0.003	0.006
D	2.800	3.000	0.110	0.118
E	1.200	1.400	0.047	0.055
E1	2.250	2.550	0.089	0.100
e	0.950 TYP		0.037 TYP	
e1	1.800	2.000	0.071	0.079
L	0.550 REF		0.022 REF	
L1	0.300	0.500	0.012	0.020
$\theta$	0°	8°	0°	6°

• SOT-23-5

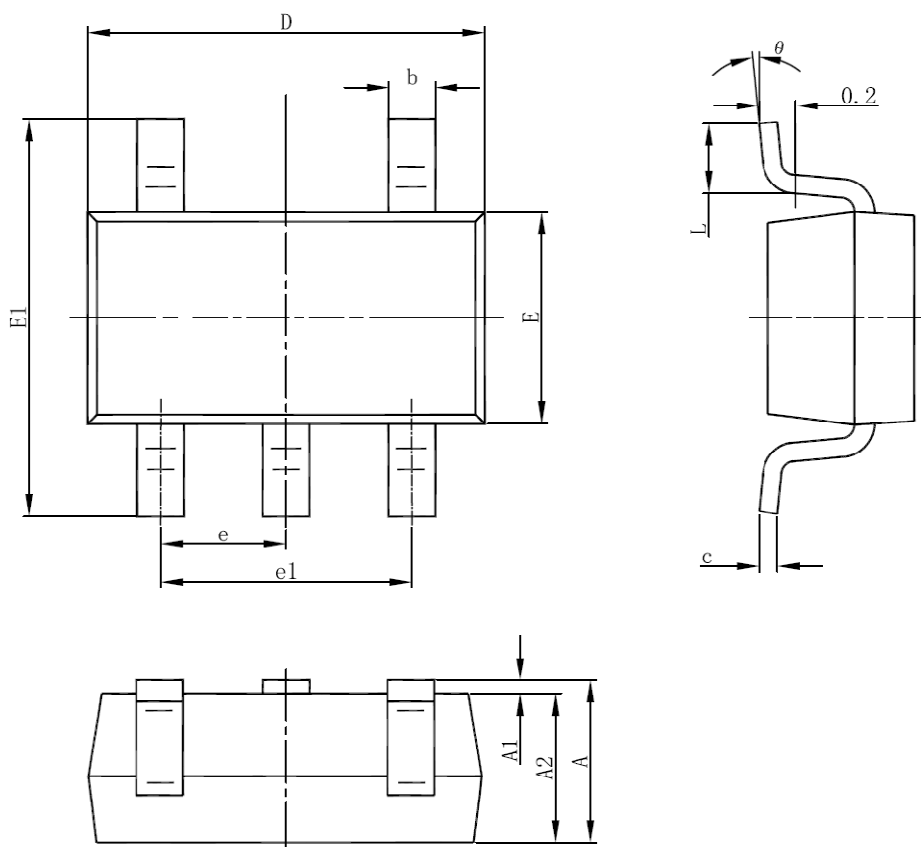

Symbol	Dimensions In Millimeters		Dimensions In Inches	
	Min	Max	Min	Max
A	1.050	1.250	0.041	0.049
A1	0.000	0.100	0.000	0.004
A2	1.050	1.150	0.041	0.045
b	0.300	0.500	0.012	0.020
c	0.100	0.200	0.004	0.008
D	2.820	3.020	0.111	0.119
E	1.500	1.700	0.059	0.067
E1	2.650	2.950	0.104	0.116
e	0.950(BSC)		0.037(BSC)	
e1	1.800	2.000	0.071	0.079
L	0.300	0.600	0.012	0.024
θ	0°	8°	0°	8°



• SOT-343

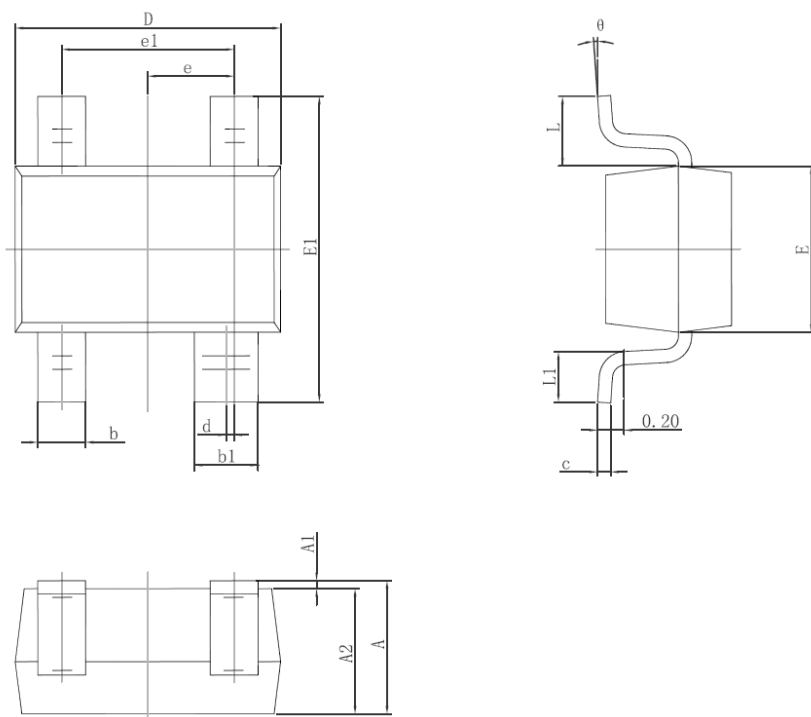

Symbol	Dimensions In Millimeters		Dimensions In Inches	
	Min.	Max.	Min.	Max.
A	0.900	1.100	0.035	0.043
A1	0.000	0.100	0.000	0.004
A2	0.900	1.000	0.035	0.039
b	0.250	0.400	0.010	0.016
b1	0.350	0.500	0.014	0.020
c	0.080	0.150	0.003	0.006
d	0.050 TYP.		0.002 TYP.	
D	2.000	2.200	0.079	0.087
E	1.150	1.350	0.045	0.053
E1	2.150	2.450	0.085	0.096
e	0.650 TYP.		0.026 TYP.	
e1	1.200	1.400	0.047	0.055
L	0.525 REF.		0.021 REF.	
L1	0.260	0.460	0.010	0.018
$\theta$	0°	8°	0°	8°

- SOT-89-3

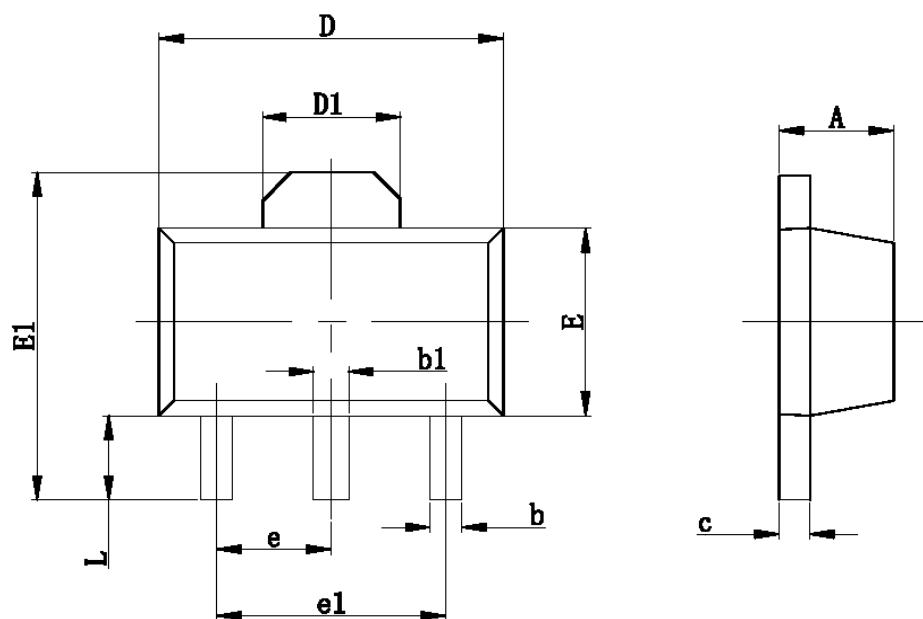

Symbol	Dimensions In Millimeters		Dimensions In Inches	
	Min	Max	Min	Max
A	1.400	1.600	0.055	0.063
b	0.320	0.520	0.013	0.197
b1	0.400	0.580	0.016	0.023
c	0.350	0.440	0.014	0.017
D	4.400	4.600	0.173	0.181
D1	1.550 REF		0.061 REF	
E	2.300	2.600	0.091	0.102
E1	3.940	4.250	0.155	0.167
e	1.500 TYP		0.060 TYP	
e1	3.000 TYP		0.118 TYP	
L	0.900	1.200	0.035	0.047

• TO-92

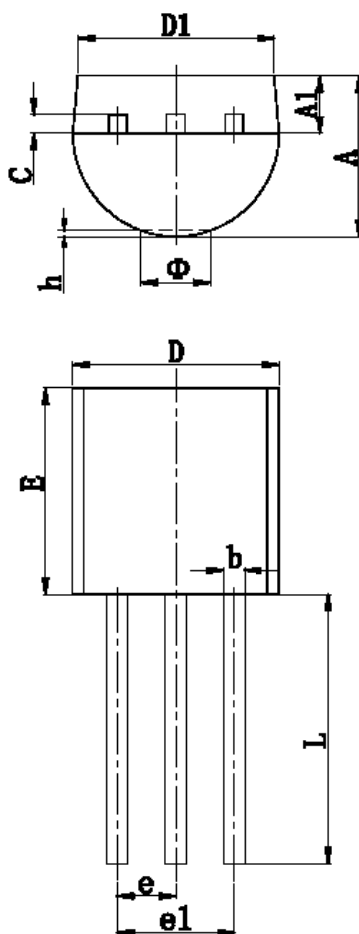

Symbol	Dimensions In Millimeters		Dimensions In Inches	
	Min	Max	Min	Max
A	3.300	3.700	0.130	0.146
A1	1.100	1.400	0.043	0.055
b	0.380	0.550	0.015	0.022
c	0.360	0.510	0.014	0.020
D	4.400	4.700	0.173	0.185
D1	3.430		0.135	
E	4.300	4.700	0.169	0.185
e	1.270 TYP		0.050 TYP	
e1	2.440	2.640	0.096	0.104
L	14.100	14.500	0.555	0.571
$\phi$		1.600		0.063
h	0.000	0.380	0.000	0.015

© Nanjing Chipower Electronics Inc.

Chipower cannot assume responsibility for use of any circuitry other than circuitry entirely embodied in a Chipower product. No circuit patent license, copyrights or other intellectual property rights are implied. Chipower reserves the right to make changes to their products or specifications without notice. Customers are advised to obtain the latest version of relevant information to verify, before placing orders, that information being relied on is current and complete.